

© COPYRIGHT 1972 BY AMP INCORPORATED, HARRISBURG, PA.
 ALL INTERNATIONAL RIGHTS RESERVED. AMP INCORPORATED PRODUCTS
 COVERED BY U. S. AND FOREIGN PATENTS AND/OR PATENTS PENDING.

		REVISIONS				
P	F	ZONE	LTR	DESCRIPTION	DATE	APPROVED
✓	✓		D	REV. REMOVED'S, REDRAWN	3/12/81	JHM
✓	✓		E	OBSOLETE - 1 PER G-4263	10/88	AG

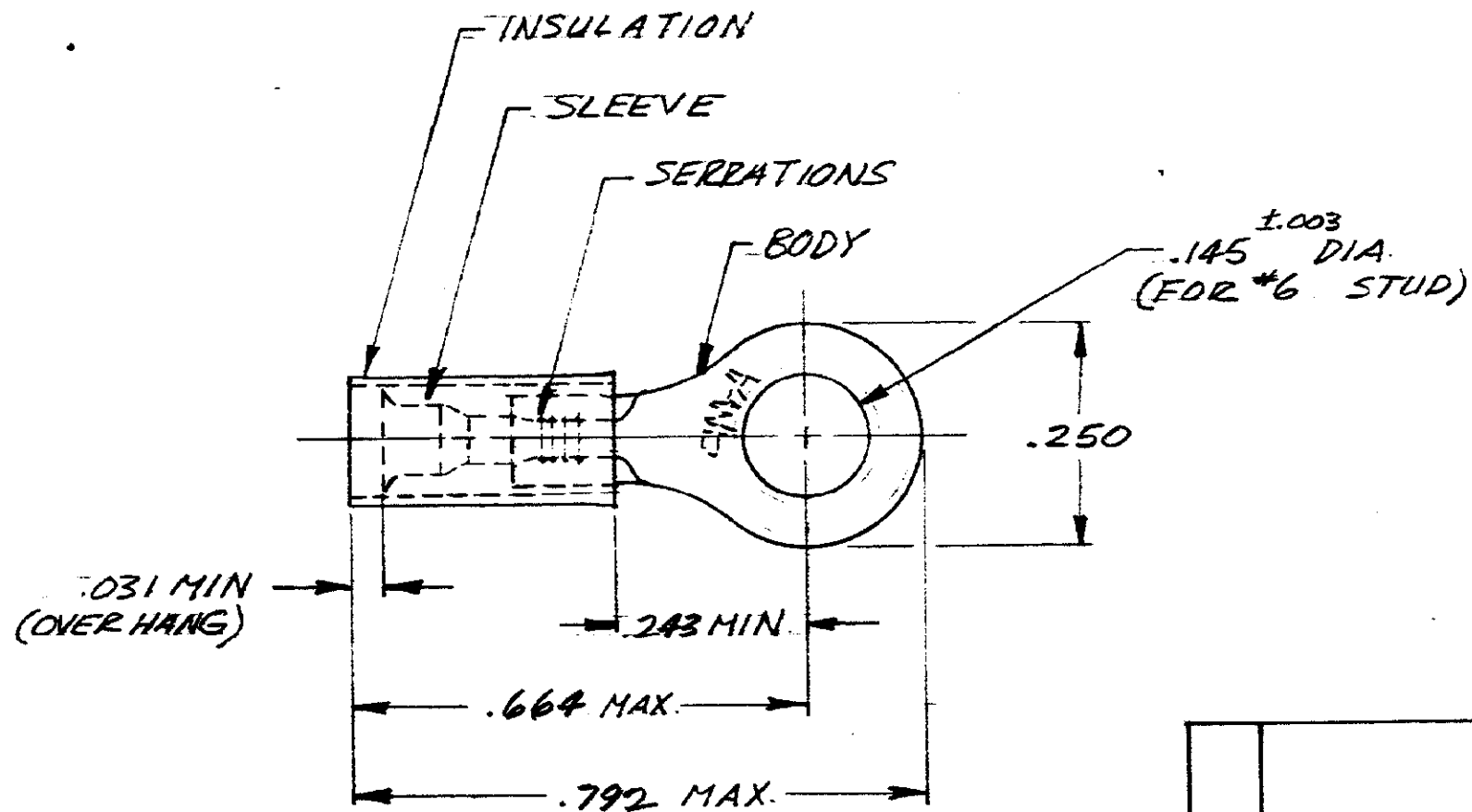

FOR .050 TO .105 WIRE INSULATION DIA.
 TONGUE MATERIAL THICKNESS = .027 ±.001

MUST BE CRIMPED WITH 22-18 OR 22-16
 PIDG (RED) TOOL

QTY	DESCRIPTION	MATERIAL & FINISH	PART NO
1	WIRE TERMINAL	SLEEVE: COPPER (ASTM B3) TIN PL (MIL-T-10727) BODY: COPPER (QQ-C-576) TIN PL (MIL-T-10727) INSULATION: NYLON (MIL-M-20693) TYPE I COLOR: YELLOW	53073

53073	53073-1	OBSOLETE
PART NO.	PT. NO. ON TAPE	

UNLESS OTHERWISE SPECIFIED DIMENSIONS ARE IN INCHES. TOLERANCES ON: DECIMALS ±.000 ANGLES ±	CONTRACT NO	AMP INCORPORATED Harrisburg, Pa.
	DR <i>R Brown 13-12-81</i>	
MATERIAL (SEE TABLE)	CHK <i>JM</i> 3/13/81	NAME TERMINAL
FINISH (SEE TABLE)	APPR <i>John</i> 3/13/81	PIDG - RING TONGUE WIRE SIZE: 26-24
	DSGN APPD	SIZE B CODE IDENT NO 00779 DRAWING NO 53073
	OTHER APPD	SCALE N.T.S. SHEET 1 OF 1

CUSTOMER DRAWING